

toll-quality 8 kbps voice

MICOM First to Implement ITU G.729 Standard

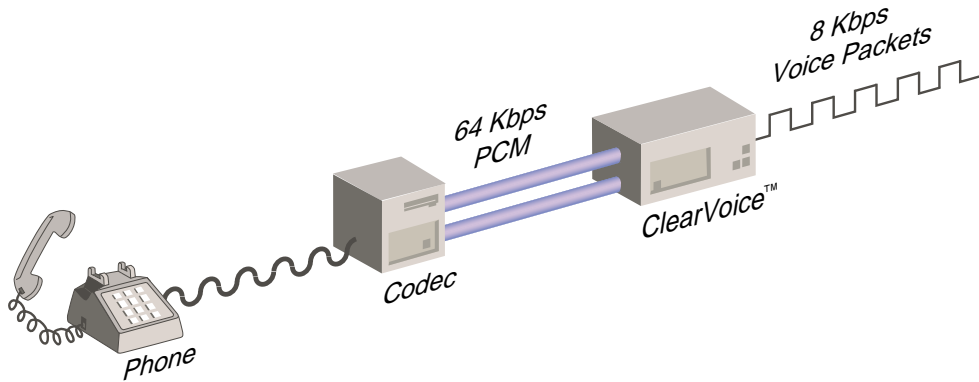

CLEARVOICE

Introducing ClearVoice™

ClearVoice is a new suite of advanced technologies that deliver toll-quality voice with exceptional bandwidth efficiency to MICOM Marathon® and NetRunner® integration products. Integrated networking lets voice and fax traffic ride with data and LAN traffic over wide-area communications links. Companies can reduce their telecommunications costs by eliminating interoffice toll charges and voice tie lines.

Based on the new ITU (International Telecommunications Union) G.729 voice compression standard, ClearVoice also includes MICOM's industry-leading voice switching, fax and modem demodulation, echo cancellation, silence suppression and background noise regeneration techniques. This combination of technologies provides:

- **Toll-Quality Voice**
ClearVoice delivers exceptional voice quality at low 8 Kbps compression rates. Customers can reap the cost-saving benefits of integration without compromising voice quality.
- **High Bandwidth Efficiency**
Voice and fax traffic use minimal bandwidth, which frees more bandwidth for data and LAN communications traffic.
- **Standards-Based Reliability**
Customers can rely on ClearVoice because it implements the latest standard for voice digitization from the ITU. This independent organization defines the standards for public telephone networks worldwide.

ITU G.729 Background

After months of study, the ITU ratified a new voice compression standard called G.729 at their November 1995 Plenary Session. The objective of the Study Group was to identify a voice compression algorithm that could transport voice at 8 Kbps with quality equivalent to 32 Kbps ADPCM (G.724). ADPCM is used to provide toll quality voice in public telephone networks worldwide.

The Group determined that CS-ACELP (Conjugate-Structured Algebraic-Code-Excited Linear-Predictive) algorithm would provide the foundation for the new standard. During the process, recommendations from AT&T, France Telecom, and NTT (Japan) were incorporated to improve the performance of systems based on the new standard.

CS-ACELP produces a 10-byte speech frame every 10 milliseconds based on 80 samples of standard or linear PCM (64 Kbps Pulse Code Modulation). The algorithm delivers an exceptionally high level of voice quality with minimal delay. CS-ACELP was designed for implementation by advanced Fixed Point Digital Signal Processors (DSPs) like those used in Marathon/NetRunner integration products.

delivering toll-quality voice

Bandwidth Savings

ClearVoice technology packages G.729 speech frames to consume approximately 9 Kbps on a private leased line and 10.6 Kbps on a frame relay link, including overhead. Bandwidth savings are optimized by Silence Suppression, which allows the gaps in speech on one channel (caused by the silences inherent in voice conversations) to be filled by actual speech or data from another channel. With Silence Suppression and other bandwidth efficiencies, the requirement is reduced to approximately 4 Kbps average bandwidth during a conversation. The typical requirement is even less because the voice channel is unused 50-75% of the time.

Because of these efficiencies, ClearVoice technology allows more voice channels to operate with less bandwidth and better voice quality. For example:

- Two toll-quality voice channels can be carried over a 19.2 Kbps *MicroBand* ATM private leased line using an analog modem, with 10-12 Kbps available for data.
- Seven toll-quality voice channels can be carried over a 64 Kbps CIR frame relay link.
- A full complement of 30 toll-quality voice channels on an E1 line can be condensed to 256 Kbps on a private leased line or frame relay link.
- A full complement of 24 toll-quality voice channels on a T1 line can be condensed to 192 Kbps on a leased line or 256 Kbps CIR on a frame relay link.

In the last example, the extraordinary efficiency of ClearVoice would still allow for 50 Kbps of synchronous data traffic or 100 Kbps of asynchronous or LAN traffic with all twenty-four voice channels active!

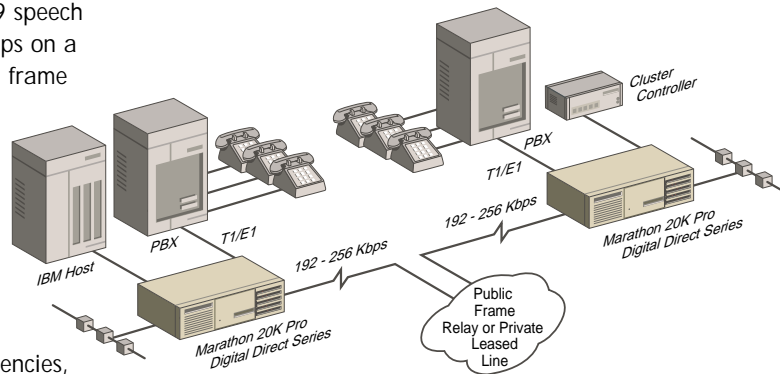

Systems Supported By ClearVoice

ClearVoice operates on Marathon and NetRunner integration products at Revision 5.0 system software equipped with the new ClearVoice Modules (CVM) or Turbo Universal Voice Modules (TUVM). It also is supported on Marathon 3K integral voice/fax channels and in the Digital Voice Modules (DVM) in the T1 and E1 Digital Direct Series.

Building for the Future

ClearVoice offers the most highly efficient toll-quality technology on the market today based on the latest industry standard in voice compression. It will provide the foundation for future enhancements on all new voice/fax modules from MICOM.

MICOM Communications Corp.

A Nortel (Northern Telecom) Company
4100 Los Angeles Avenue
Simi Valley, California 93063-3397

Tel: (805) 583-8600

Fax: (805) 583-1997

Internet Web page: <http://www.micom.com>

E-mail address: info@micom.com

24-Hour FAXBACK System: (805) 582-7478

MICOM, Marathon, NetRunner, FrameRunner, STADIA, NETMan, MicroBand ATM, EasyRouter, ClearVoice, Voice/Fax Multiplier and  are registered trademarks or trademarks of MICOM Communications Corp. All other names or trademarks are true property of their respective companies.

Specifications subject to change without notice.

©1997 MICOM Communications Corp. All rights reserved.

For more information or the location of the MICOM Certified Distributor closest to you, call our Applications Hotline.

In the United States call:

Tel: 800-642-6687 • Fax: (800) 343-0329

In Europe, Middle East and Africa call:

Tel: 44 (0) 1252 302 200 • Fax: 44 (0) 1252 781 717

In Asia-Pacific Rim call:

Tel: 65 334 6557 • Fax: 65 334 5845

In Latin America call:

Tel: (813) 538-7719 • Fax: (813) 539-1425

850-0250-B